

Standardized Emergency Management System (SEMS) Guidelines

Part I. System Description

Section C

Local Government Level

The contents of this guideline have not been changed from the original document, however, the guideline has been reformatted to meet Americans with Disabilities Act (ADA) 508 standards.

1. Local Government Level in SEMS

Local government is one of the five levels of the Standardized Emergency Management System. The basic role of a local government is to manage and coordinate the overall emergency response and recovery activities within its jurisdiction.

A local government under SEMS is a city, county, city and county, school district, or special district. Special districts under SEMS are units of local government (other than a city, county, or city and county) with authority or responsibility to own, operate or maintain a project (as defined in California Code of Regulations Section 2900(s) for purposes of natural disaster assistance). This may include a joint powers authority established under Section 6500 et seq. of the Code.

There also exists state (e.g., CDF, CHP, State Colleges and Universities) and federal jurisdictions at the Local Government organizational level of SEMS with responsibility to manage and coordinate the overall emergency response and recovery activities within their jurisdictions. State agencies are required to use SEMS at this level and should be incorporated (or at least coordinated), as appropriate, at the SEMS Local Government or Operational Area organizational level.

Federal agencies are not required to participate in the SEMS organization. However, many federal agencies also have responsibility to manage and coordinate the overall emergency response and recovery activities within their jurisdictions and often must coordinate with other local and state jurisdictions (e.g., the USDA, Forest Service, the California Department of Forestry and Fire Protection, and local fire agencies coordinate wildfire suppression activities utilizing the SEMS Field level ICS Unified Command concept).

Cities generally are responsible for emergency response within their boundaries. Some cities contract for some municipal services from other agencies.

County government is responsible for emergency response in unincorporated areas and for some county government functions countywide. Note that county government staff

may also serve as the operational area emergency management staff. (See Part I. D. Operational Area Level.)

Special districts are primarily responsible in emergencies for restoration of services that they normally provide. They may also be responsible for safety of people at their facilities or on their property, and for warning of hazards from their facilities or operations. Some special districts may assist other local governments in the emergency response.

All local governments are responsible for coordinating with other local governments, the field response level and the operational area. Local governments are also responsible for providing mutual aid within their capabilities. (See Part I.A. for a description of the mutual aid system.)

2. SEMS Requirements for Local Governments

Local governments must comply with SEMS Regulations in order to be eligible for state funding of response-related personnel costs. SEMS Regulations require local governments to:

1. Use SEMS when;
 - a. A local emergency is declared or proclaimed, or,
 - b. The local government EOC is activated.
2. Establish coordination and communications with Incident Commanders either;
 - a. Through department operations centers to the EOC, when activated or,
 - b. Directly to the EOC, when activated,
3. Use existing mutual aid systems for coordinating fire and law enforcement resources.

4. Establish coordination and communications between the local government EOC when activated, and any federal, state or local emergency response agency having jurisdiction at an incident within the local government's boundaries.
5. Use multi-agency or inter-agency coordination to facilitate decisions for overall local government level emergency response activities.

The requirement to use SEMS includes:

- Fulfilling the management and coordination role of local government,
- Providing for the five essential SEMS functions of management, operations, planning/intelligence, logistics, finance/administration.

In using SEMS, local governments should incorporate applicable features of SEMS, as described in Part I.A., into their emergency organization and operations.

3. Emergency Operations Center (EOC)

An emergency operations center (EOC) is a location from which centralized emergency management can be performed. The use of EOCs is a standard practice in emergency management. Local governments should have designated EOCs. The physical size, staffing, and equipping of a local government EOC will depend on the size and complexity of the local government and the emergency operations it can expect to manage. The level of EOC staffing will also vary with the specific emergency situation.

A local government's EOC facility should be capable of serving as the central point for:

- Coordination of all the jurisdiction's emergency operations,
- Information gathering and dissemination,
- Coordination with other local governments and the operational area.

4. EOC Organization

SEMS Regulations require local governments to provide for five functions: management, operations, planning/intelligence, logistics, and finance/administration. These functions should be the basis for structuring the EOC organization.

Primary SEMS Function Role at Local Government Level

Management	Responsible for overall emergency policy and coordination through joint efforts of governmental agencies and private organizations.
Operations	Responsible for coordinating all jurisdictional operations in support of the emergency response through implementation of the local government's action plan.
Planning/Intelligence	Responsible for collecting, evaluating, and disseminating information; developing the local government's action plan in coordination with other functions; and maintaining documentation.
Logistics	Responsible for providing facilities, services, personnel, equipment, and materials.
Finance/Administration	Responsible for financial activities and other administrative aspects.

Other local government emergency functions may be placed under the five essential functions. Exhibit C-1 lists possible functions at the local government level. These

functions may be clustered in various ways under the five SEMS functions. See Guidelines Part II.C for additional information.

The EOC organization should include representatives from special districts, volunteer agencies and private agencies with significant response roles.

Use of Incident Command System terminology is recommended, but not required, for the hierarchy of organizational elements within the EOC:

- Section
- Branch
- Group
- Unit

The five essential SEMS functions would normally be established as sections within the EOC using the ICS terminology. Other functions, such as the MHFP functions would be included as branches, groups, or units. It is not necessary to use all four hierarchical levels in the EOC. For example, many EOCs use only sections, branches and units.

For the purposes of these guidelines, we will use the position title "coordinator" to refer to the lead person of each of the organizational elements in the EOC. The term coordinator is used because the role of EOC elements is to coordinate.

Exhibit C-1

Example Local Government Emergency Functions

(Functions that could be organizationally placed under the five SEMS functions)

<p>Functions and Subelements from Multi-hazard Functional Planning Guidelines</p>	<p>Other Functions*</p>
<p>Communications Alerting & Warning Situation Analysis & Reporting Reconnaissance Damage Assessment Public Information Radiological Protection Fire & Rescue Law Enforcement & Traffic Control Medical Public Health Coroner Care & Shelter Registration & Inquiry Lodging (shelter) Feeding Movement Rescue Construction & Engineering Street/Route Recovery Structure & Facility Inspection Debris Removal Flood Control Supply/Procurement Personnel Transportation Utilities</p>	<p>Animal Control Advance Planning Compensation & Claims Cost Accounting Documentation Demobilization Planning Facilities Management Food Management Fuels Management Hazardous Materials Control Information Systems Liaison Purchasing Recovery Planning Risk Management Safety Sanitation Temporary Housing Time Recording Vital Records Control Water Resources Welfare Services</p> <p>*Some of these functions could be considered subelements of MHFP functions.</p>

Local governments may use other position titles within their EOC organization. Three options are shown below.

<u>A. Coordinators</u>	<u>B. ICS Position Titles</u>	<u>C. Combined Terminology</u>
EOC Director	EOC Director	EOC Director
- Section Coord.	- Section Chief	- Section Chief
- Branch Coord.	- Branch Director	- Branch Coord.
- Group Coord.	- Group Supervisor	- Group Coord.
- Unit Coord.	- Unit Leader	- Unit Coord.

The ICS concept of the General Staff also applies at in the EOC. Using this concept, the Coordinators for Operations, Planning/Intelligence, Logistics, and Finance/Administration constitute the EOC General Staff.

The EOC Director and General Staff function as an EOC management team. The General Staff are responsible for:

- Overseeing the internal functioning of their section,
- Interacting with each other, the EOC Director, and other entities within the EOC to ensure the effective functioning of the EOC organization.

The EOC Director may wish to establish functions of Liaison and Public Information at individual, unit, group or branch level. In any event these positions should always be involved in the EOC planning sessions.

An EOC Coordinator may be designated to assist the EOC Director. The EOC Coordinator facilitates the overall functioning of the EOC and coordination with other agencies and SEMS levels. The EOC Coordinator should be a member of the EOC Director's Staff. The EOC Coordinator position would normally be filled by the local government's emergency management coordinator (or emergency services coordinator). The authority, duties, and responsibilities of this individual will vary depending on the size of the jurisdiction and the needs of the organization.

Exhibits C-2 and C-3 on the following pages show example EOC organizations for small and large jurisdictions. The examples show modular EOC organizations. Organizational elements are staffed as needed for the situation. Exhibit C-4 shows how an EOC organization can evolve over time during a disaster.

Exhibit C-2
Example
Small Local Government EOC Functional Organization

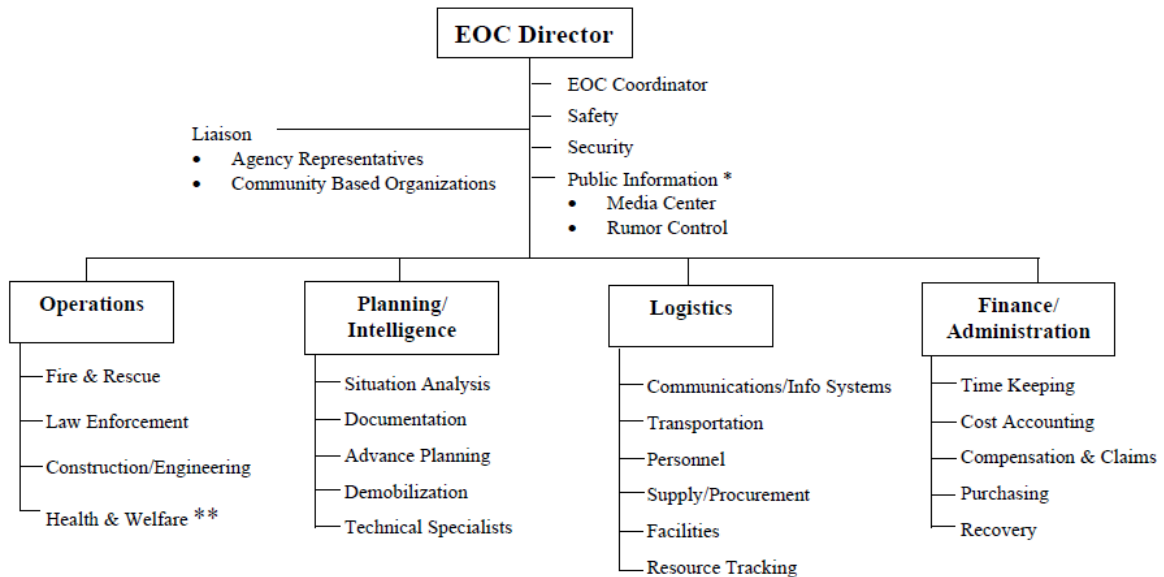

* Public Information functions may be organized through use of assistant information officers or as units if necessary.

** Normally coordinated by county, but a local coordinator may be designated if needed.

Exhibit C-3
Example
Large Local Government EOC Functional Organization

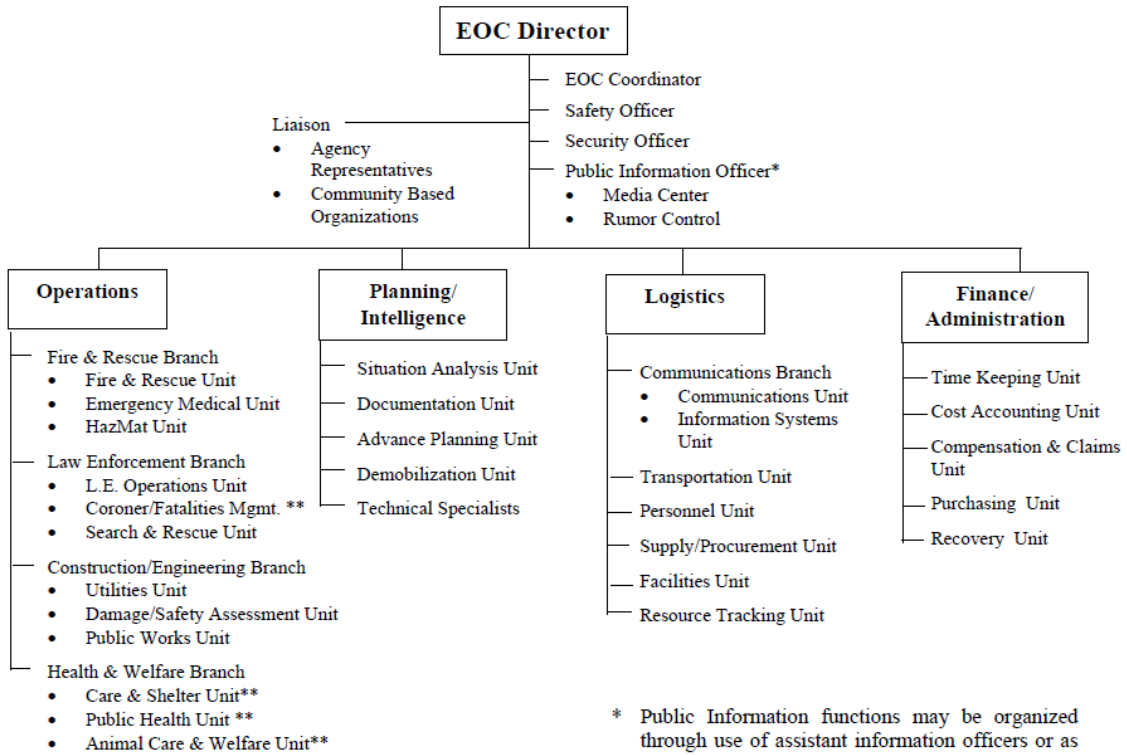

* Public Information functions may be organized through use of assistant information officers or as units if necessary.

** Normally coordinated by county, but a local coordinator may be designated if needed.

Each jurisdiction must determine the appropriate organization for the functions to be performed.

Exhibit C-4
Example
Modular Changes In An EOC Organization During A Disaster

Period 1
(Level 1 - Minimum)

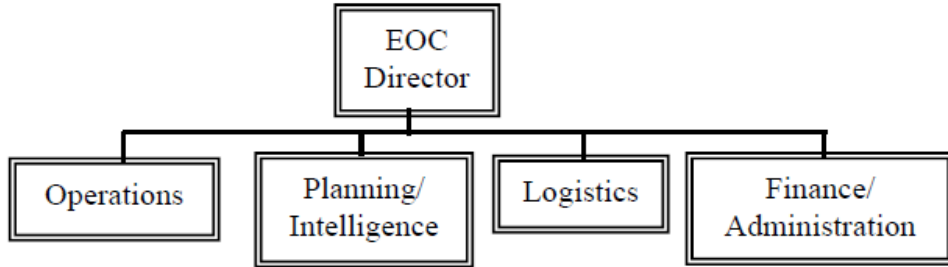

Period 2
(Level 2)

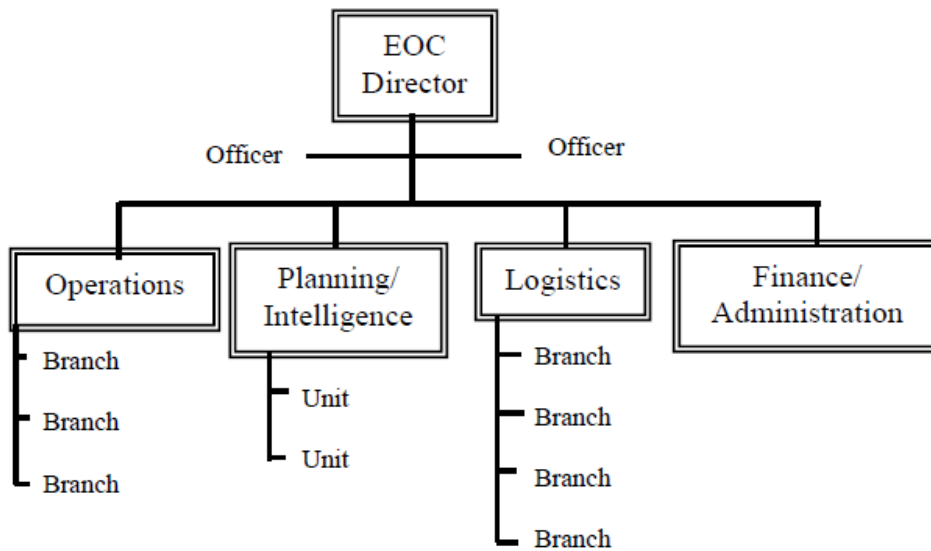

Exhibit C-4
(Continued)

Example

Modular Changes In An EOC Organization During A Disaster

Period 3

(Level 3 - Maximum)

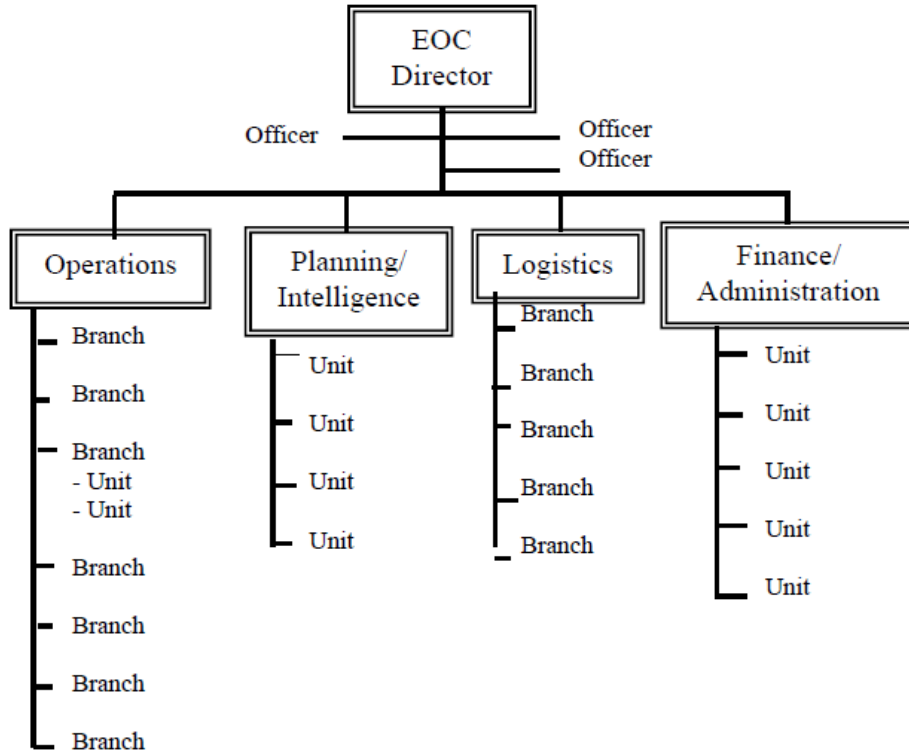

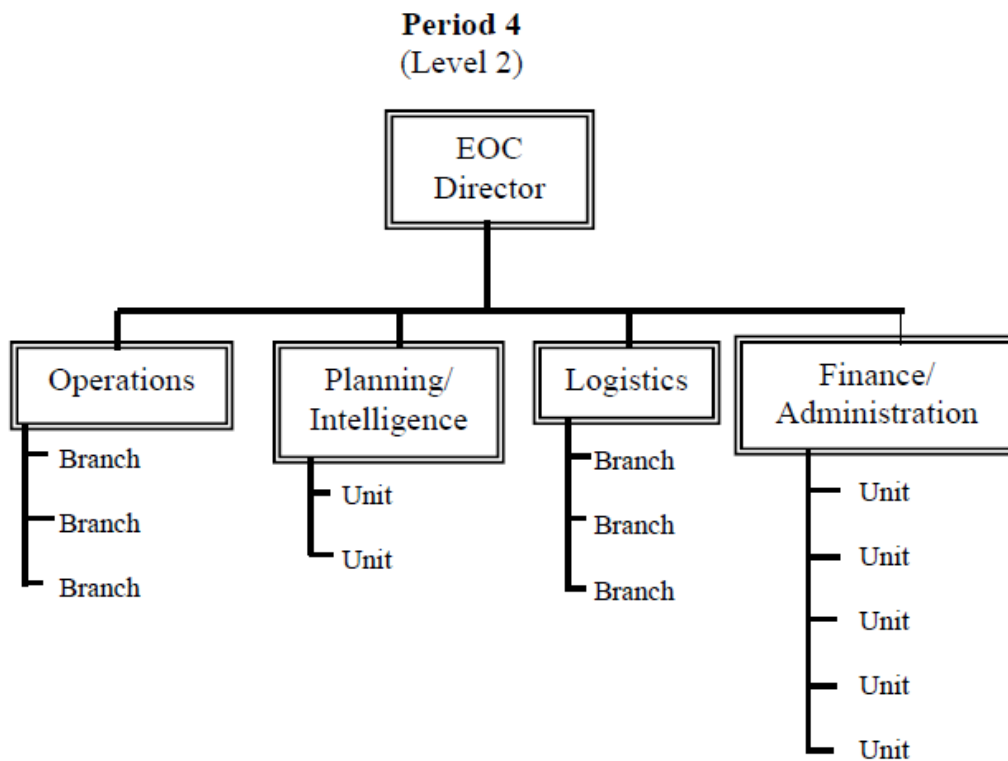

5. Activation

Activation of the local government level means that one local government official implements SEMS as appropriate to the scope of the emergency and the local governments role in response to the emergency.

The local government level is activated when field response agencies need support.

The local official(s) implementing SEMS may function from the EOC or from other locations depending on the situation. Each local government should establish criteria for activating its EOC.

Activated EOCs may be partially or fully staffed to meet the demands of the situation. It is recommended that local government procedures provide for varying EOC staffing levels that can be applied to various situations. An example of activation criteria and staffing levels for a local government EOC is shown in Exhibit C-5.

The operational area should be notified when a local government EOC is activated.

6. Action Planning

Action Planning is an essential element of SEMS at the local government level. Action planning is an important

Management tool that involves:

A process for identifying priorities and objectives for emergency response coordinating, supporting or recovery efforts,

- Plans, which document the priorities and objectives, and the tasks and personnel assignments, associated with meeting the objectives.

The action planning process should involve the EOC Director and General Staff along with other EOC elements, special district representatives and other agency representatives, as needed. The Planning/Intelligence Section is normally responsible for development of the action plan and for facilitation of action planning meetings.

Action plans are developed for a specified operational period which may range from a few hours to 24 hours. The operational period is determined by first establishing a set of priority actions that need to be performed. A reasonable time frame is then established for accomplishing those actions. The action plans need not be complex, but should be sufficiently detailed to guide EOC elements in implementing the priority actions. Part III of the Guidelines provides further information on developing action plans.

Example Local Government EOC Activation Guide

Event Situation ¹	Activation Level	Minimum Staffing ²
Severe Weather Advisory Small incidents involving 2 or more departments Earthquake Advisory Flood Watch	One	EOC Director Planning Section Coordinator
Moderate Earthquake Wildfire affecting developed area		

Major wind or rain storm Two or more large incidents involving 2 or more departments Imminent Earthquake Alert Major scheduled event (such as World Cup, Papal visit, Olympics, etc.)	Two	EOC Director All Section Coordinators Branches and Units as appropriate to situation Liaison Representatives as appropriate.
Major city or regional emergency. Multiple departments with heavy resource involvement Major earthquake.	Three	All EOC Positions

¹ Local governments and the operational area should work together to develop consistent activation criteria and levels that are common with the operational area.

² Minimum staffing may vary with the size of the local government.

7. Multi-agency or Inter-Agency: Coordination at the Local Government Level

Multi-agency or inter-agency coordination is important for;

- Establishing priorities for response,
- Allocating critical resources,
- Developing strategies for handling multi-agency response problems,
- Sharing information,
- Facilitating communications.

Inter-agency Coordination in the EOC

To be consistent with the Approved Course of Instruction, the term Multi-agency or inter-agency coordination, as defined in the SEMS regulation will be shortened to Inter-agency coordination.

Inter-agency Coordination is an integral part of the functioning of a local government EOC. The EOC is staffed by representatives from the local government's departments and agencies who work together at the EOC to coordinate the local government's emergency response. Representatives from outside agencies including special districts, volunteer agencies and private organizations may also participate at the EOC with departmental representatives in coordinating the local government response effort. Coordination with agencies not represented in the EOC may be accomplished through communications.

Involvement of the local government's departmental representatives and appropriate liaison representatives in the action planning process at the EOC is essential for effective emergency management and provides an important focus Inter-agency coordination. In addition, the EOC Director or General Staff may convene meetings for Inter-agency coordination purposes as needed.

Establishing an Inter-agency Coordination Group

In some situation, it may be useful to establish formally a Inter-agency coordination group to develop consensus on priorities, resource allocation and response strategies. A formal Inter-agency coordination group can be especially useful when a particular response problem or issue requires coordination with numerous agencies not usually represented in the local government's EOC. An Inter-agency coordination group can unify multiple jurisdictions that have statutory responsibilities for the emergency. It provides a forum, similar to unified command at the field level, where responsible jurisdictions can establish common goals and objectives and assure their authorities have not been compromised. Such a group may be developed through pre-event planning for certain contingencies as a part of the jurisdiction's emergency management organization. This group will provide direction to the EOC for allocation of scarce resources.

A local government level inter-agency coordination group may function within the EOC or at another location. An inter-agency coordination group may also function through conference calls. Whether physically at the EOC or at another location, the inter-agency coordination group should remain connected to the local government EOC, and perform as an extension of an established EOC function. Priorities and objectives developed through the group should be incorporated into the action plan developed at the EOC. Objectives agreed to by the group should be implemented through the EOC.

Local government representatives may participate with other local governments and other agencies in an inter-agency coordination group organized by another local government, operational area or regional level.

8. Coordination with the Field Response level

Coordination among SEMS levels is clearly necessary for effective emergency response. The local government level must have the capability to coordinate with Incident Command Systems for any field response within its boundaries.

In a major emergency, a jurisdiction's EOC may be activated to coordinate the overall response while the Incident Command System is used by field responders to manage

the incident. Incident Commanders may report to department operations centers (DOCs), which in turn will coordinate with the EOC. Alternatively, in some jurisdictions Incident Commanders may report directly to the EOC, usually to their counterpart departmental staff in the Operations Section.

It is also possible in a large city or county for Area Commands to be established between the Incident Command teams and the EOC. During a major jurisdiction-wide disaster, the jurisdiction may be divided into areas, with an Area Command overseeing the Incident Command teams within each area. The Area Commands would receive policy direction from the EOC.

Another scenario for EOC -Area Command interactions would be the occurrence of several similar type incidents located in close proximity but in different jurisdictions. A Unified Area Command may be established to oversee Incident Commands operating in general proximity to each other. The Unified Command would coordinate with activated local government EOCs.

Area Command is discussed in detail in the Field Level Course, see Part III.

Field to Local Government Coordination and Communications in a Major Area wide Disaster

Example A

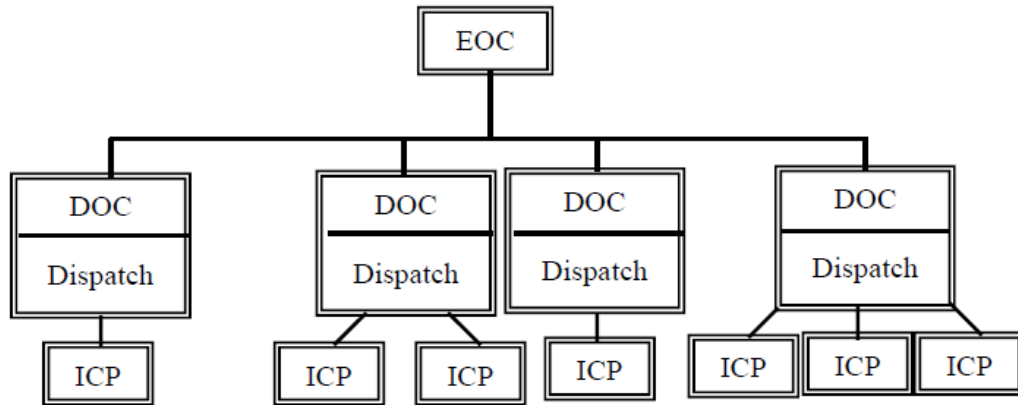

Example B

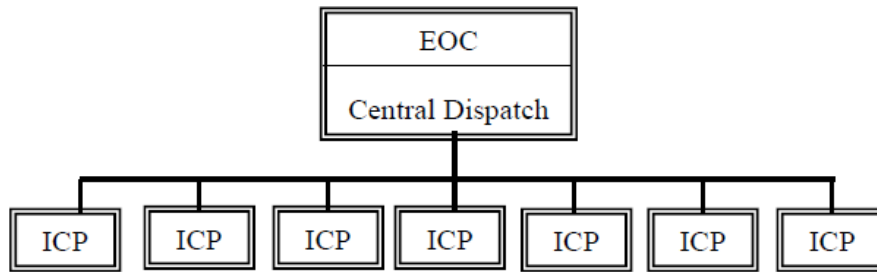
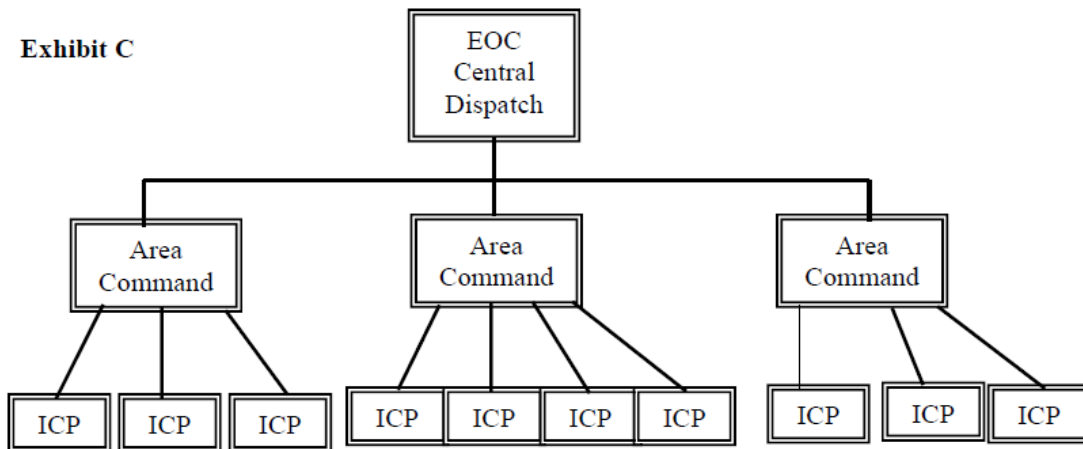

Exhibit C-6
(Continued)

Field to Local Government Coordination and Communications in a Major Area wide Disaster

Exhibit C



9. Coordination with the Operational Area Level

Coordination and communications should be established between activated local government EOCs and the operational area. Direct communications and coordination should be established between city EOCs and the operational area EOC when activated, as illustrated in Exhibit C-7, Direct communications and coordination also should be established between the county government EOC and the operational area EOC if they are physically separate.

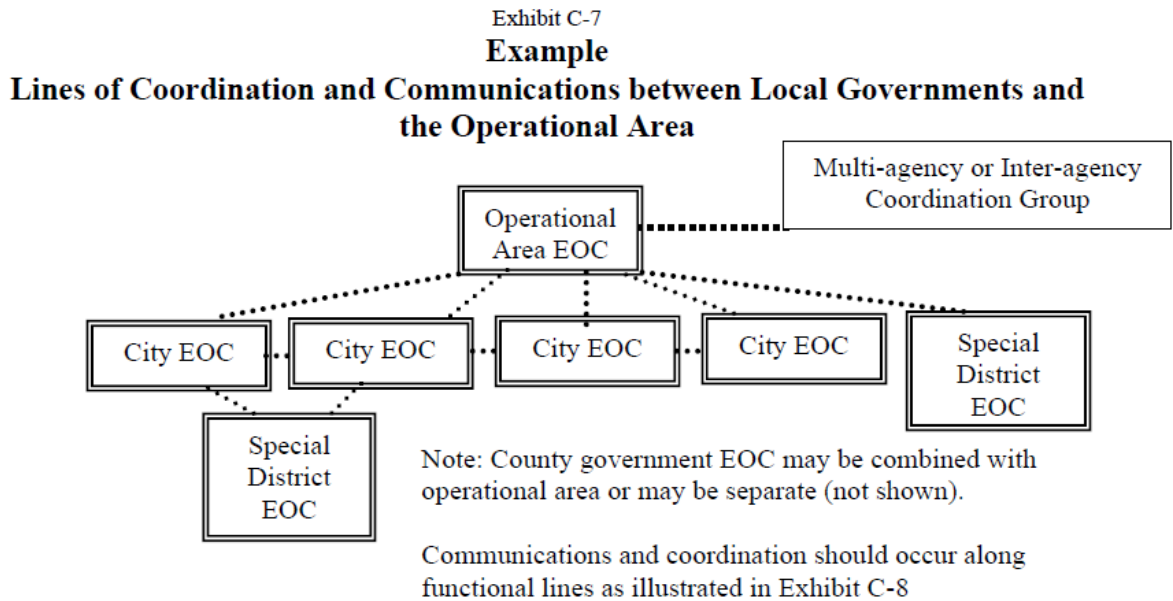

Local Government EOC - Operational Area EOC Primary Interactions

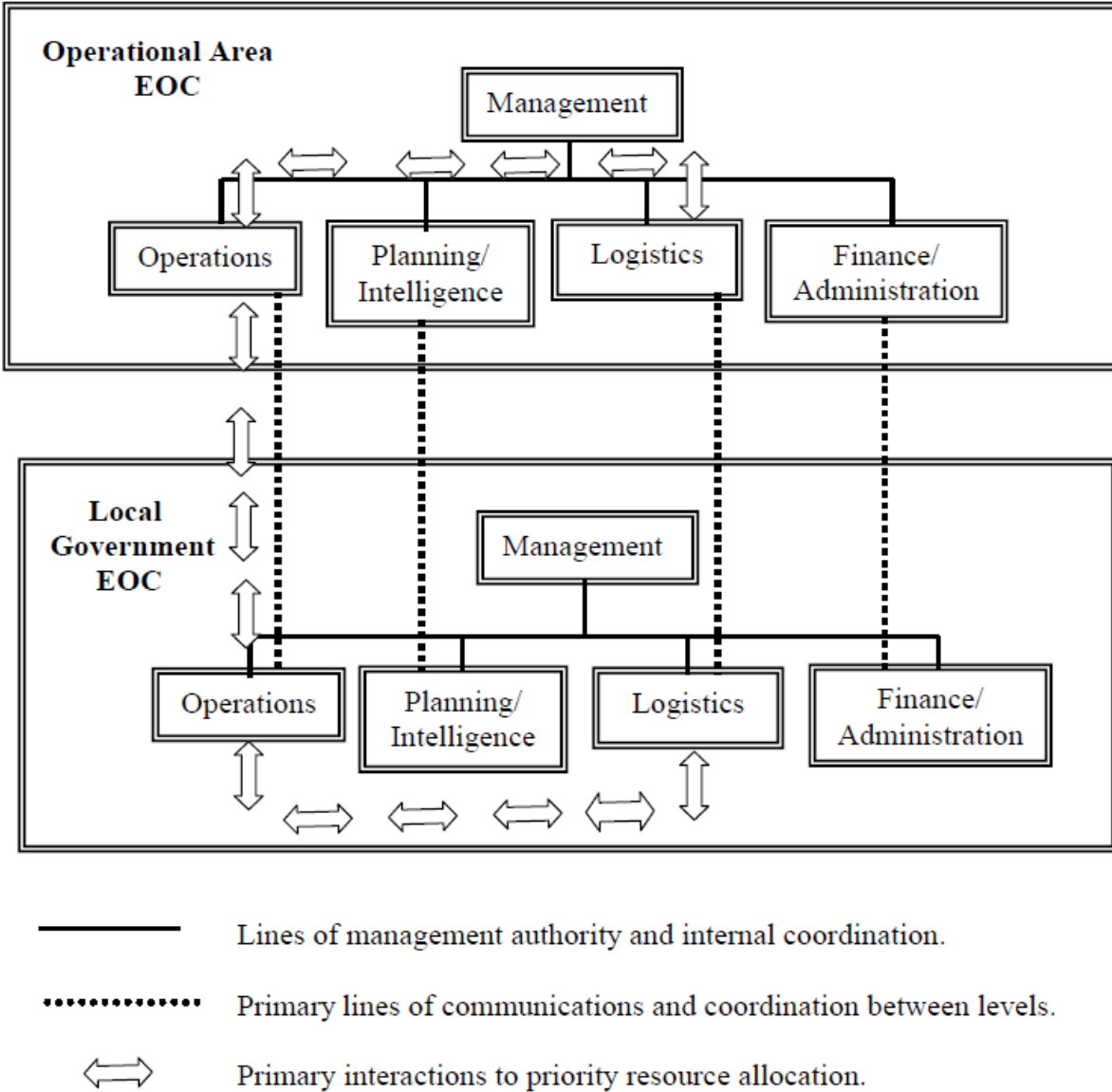

Coordination of resource requests should be done in accordance with agency policy. This requires close communications and coordination between the operations and logistics functions at both the local government and operational area levels. This relationship is vital particularly when there are multiple requests for similar resources or when resources are scarce.

A representative from every activated city EOC and from county government should be at the operational area EOC, whenever feasible. In operational areas with a large number of cities, it may not always be practical to have representatives from every city EOC at the operational area EOC. For cities with very small staffs, it may not be feasible to send a representative to the operational area EOC. The operational area and cities should work together to develop arrangements to ensure that adequate coordination and information exchange occurs when city representatives are not present at the operational area EOC.

10. Special District Involvement

Special districts are local governments in SEMS. The emergency response role of special districts is generally focused on their normal services. During disasters, some types of special districts will be more extensively involved in the emergency response by assisting other local governments.

Coordination and communications should be established among special districts that are involved in the emergency response, other local governments, and the operational area. This may be accomplished in various ways depending on the local situation. Relationships among special districts, cities, county government, and the operational area are complicated by overlapping boundaries and by the multiplicity of special districts. Special districts need to work with the local governments in their service areas to determine how best to establish coordination and communications in emergencies. The following discusses some situations and possible ways to establish coordination.

The simplest situation is when a special district is wholly contained within a single city or within a county unincorporated area. Usually in this case, the special district should have a representative at the EOC of the city or county in which it is located and direct communications should be established between the special district EOC and the city or county EOC. An exception may occur when there are many special districts within a large city or county.

Typically, special district boundaries cross municipal boundary lines similar to state emergency response agencies. A special district may serve several cities and county unincorporated areas. Some special districts serve more than one county. Ideally, a special district involved in the emergency response will have representatives at all activated city or county EOCs within its services area. However, this may not be practical when many jurisdictions within its services area are affected. One alternative may be to focus coordination at the operational area level and designate a representative to the operational area EOC to work with other local government representatives at the EOC.

When there are many special districts within one city or within the county unincorporated area, it may not be feasible for the city or county EOC to accommodate representatives from all special districts during area-wide disasters. In such cases, the city or county should work with the special districts to develop alternate ways of establishing coordination and communications. Some alternatives to consider:

- Representatives at the EOC only from designated key special districts --- telecommunications with other special districts.
- One representative from each type of special district who would communicate with other special districts of the same type.
- Establish a special district coordination center for a particular type of special district, such as a water district coordination center, that communicates with the jurisdiction EOC. This arrangement may be established for the operational area.

11. Coordination with Community Based Organizations and Collaboratives

Community Based Organizations differ in size, name, organizational structure and procedure, but all share a common bond of addressing the disaster concerns of individuals and special needs communities. They are often the best resources for a

particular population. They bring a level of expertise and assistance to the community that is not often possible with the larger, traditional emergency service providers.

They assist in providing assurances that the needs of under served populations and the complexity of human service issues in disasters are addressed. They have the capacity to organize teams of volunteers to do the outreach necessary to reach these persons following disasters. In many instances a strong collaboration will lead to better assist individuals recover from personal losses suffered in major emergencies and disasters. Ongoing relationships are essential in building the capacity of Community Based Organizations to respond to client needs in local disasters.

The Operational Area should establish coordination with Community Based Organizations that have multi-jurisdictional or countywide response roles. Community Based Organizations that play key roles in response should have representation at the Operational Area EOC.

If a Community Based Organization supports several functions and has only one representative at the EOC, the agency representative should be located at the liaison area as an Agency Representative. If an agency is supporting one function only, its representative may be located with that functional element. For example, in some operational areas, the American Red Cross representative may be part of the staff for the Care and Shelter element of the EOC.

Multiple Community Based Organizations may form a Collaborative, which may appoint a Lead Agency Representative to represent them in the EOC. Other means of communications with individual agencies could be telecommunications.

Many Operational Areas have formed Collaboratives. If an Operational Area Collaborative has been formed and is needed for a city specific response, the request for these resources should be coordinated through the Operational Area.

If there is going to be a State response utilizing a Community Based Organization, this should be coordinated with the Operational Area and Operational Area Community Based Organizations and/or Collaboratives to assist in ensuring easy transition, non-

duplication of resources and the most efficient and effective response to the victims of the emergency.

12. Relationship to Mutual Aid Systems

Local governments request resources through established discipline-specific mutual aid systems such as fire, law enforcement, and medical. Resource requests are made to designate Operational Area Mutual Aid Coordinators who may be located at the operational area EOC or another location depending on the emergency situation and the mutual aid system. Resources not available through discipline-specific mutual aid systems are requested by local governments through the emergency services channel. Local governments place such requests to the operational area EOC when activated. The mutual aid system in California is described in Part I.A.

In addition, some local governments have specific mutual aid agreements with other nearby local governments. These agreements may provide for specific types of mutual aid in certain contingency situations or for response to defined geographic areas.